



# 5' (1.5m) UNIVERSAL RISERS For Hydraulic Gantry Systems

## FEATURES

The 5' Universal Riser is the simplest and fastest way to achieve additional lifting height. Without additional track cribbing, stacking of lifting beams, or a combination thereof, you can achieve 5' (1.5 m) of additional system height with less time and labor. Integral Drives built into the risers plug into the gantry leg's auxiliary hydraulic circuit as a nothing else needed option. Designed to accommodate models 44A, 48A, 34PT300LS/WS, and 34PT5400LS/WS with full load capacities.

Custom capacities and designs are available—contact Lift Systems or your representative for details!

## UNIVERSAL RISERS SHOWN UNDER A MODEL 44A

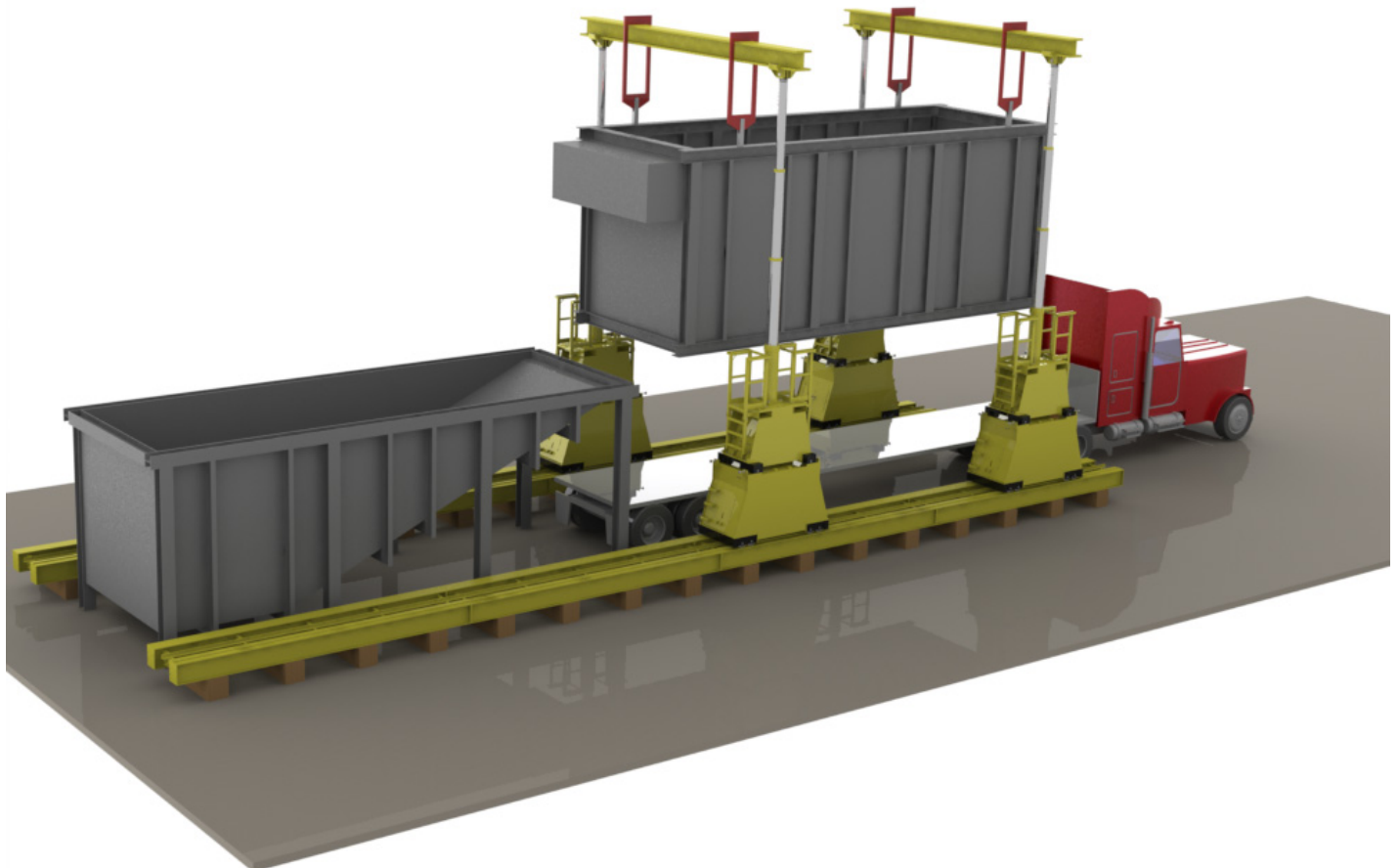

# DIMENSIONS

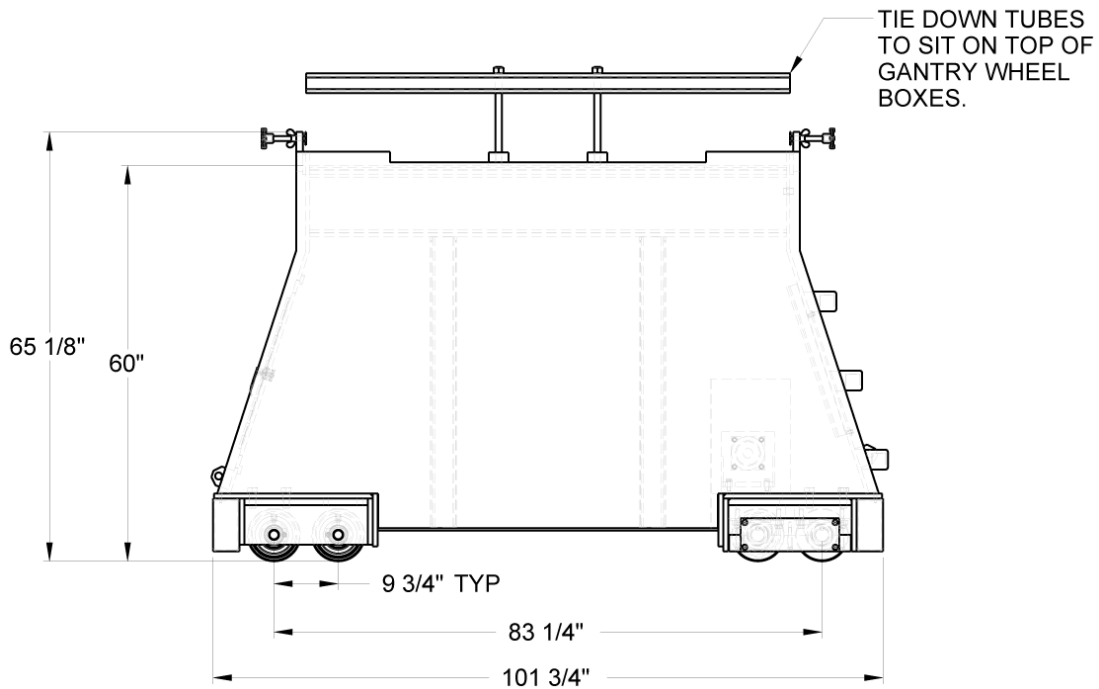

## MODEL48A BASE ON UNIVERSAL RISER



### LIFT SYSTEMS, INC.

OFFICE:  
1505 - 7th Street  
East Moline, IL 61244

MAILING ADDRESS:  
P.O. Box 906  
Moline, IL 61266

TEL: +1-309-764-9842  
FAX: +1-309-764-9848  
EMAIL: [liftit@lift-systems.com](mailto:liftit@lift-systems.com)  
WEB: [www.lift-systems.com](http://www.lift-systems.com)