



# MODEL 34PT6550WXT

## 650 Ton POWER TOWER Gantry System

### CAPACITY:

#### 4 Point

650 (585) Tons to 31'5 1/2" (9,588 mm)  
550 (500) Tons to 40'7/8" (12,214 mm)

#### 2 Point

325 (292) Tons to 31'5 1/2" (9,588 mm)  
275 (247) Tons to 40'7/8" (12,214 mm)

Max. Operating PSI: 2,650 (183 bar)

### BASE DIMENSIONS:

Length: 91" (2311 mm)  
Width: 60" (1524 mm)  
Height Retracted: 13'2" (4033 mm)  
Weight: 23,000 lbs. (10,445 kg)

### POWER UNITS:

Two (2) 400 gallon (1514 L) Power Units  
per Four Point System

Power Options: Diesel, Gasoline,  
Propane, Electric (3 phase, 440 Volt,  
60 Hz; or 3 Phase, 380 Volt, 50Hz)

Length: 100.5" (2553 mm)  
Width: 68.5" (1740 mm)  
Height: 54.75" (1391 mm)  
Weight: 8550 lbs. (3880 kg)

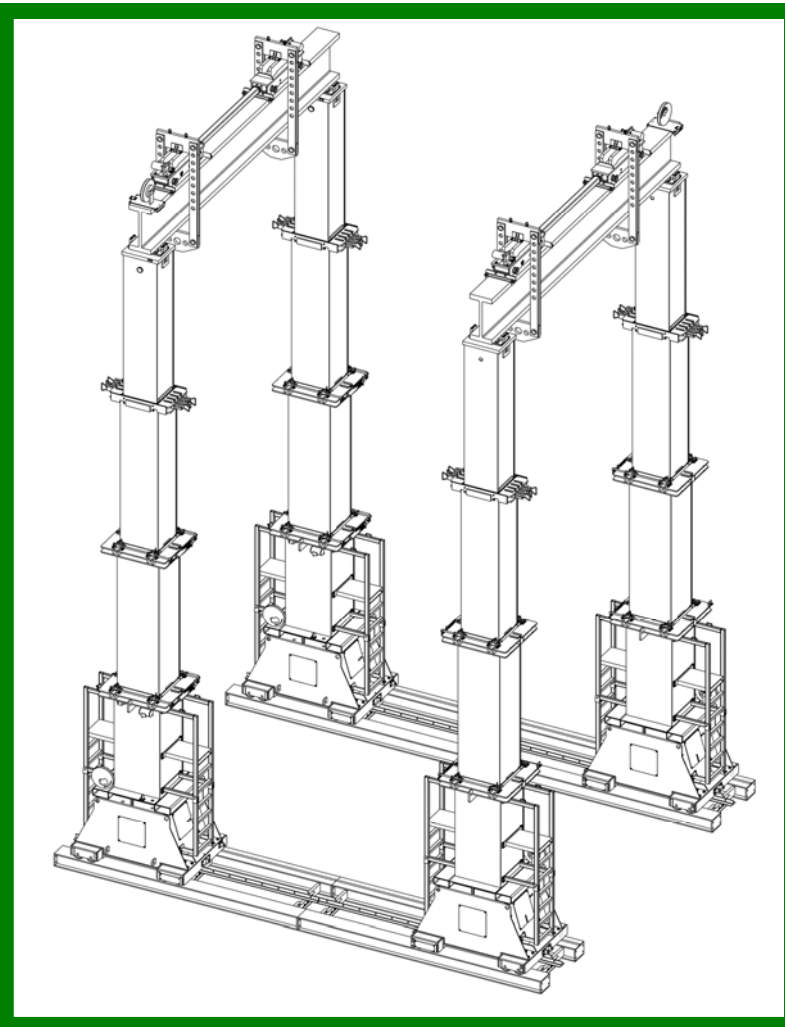

### STANDARD FEATURES

- Straightest Booms in the Industry
- Large Lift Lugs
- Safety Holding Valves
- Wedge Inter-Lock System
- Large Work Platforms
- Double Acting Cylinders

### LIFT SYSTEMS, INC.

OFFICE:  
1505 - 7th Street  
East Moline, IL 61244

MAILING ADDRESS:  
P.O. Box 906  
Moline, IL 61266

TEL: +1-309-764-9842  
FAX: +1-309-764-9848  
EMAIL: [info@lift-systems.com](mailto:info@lift-systems.com)  
WEB: [www.lift-systems.com](http://www.lift-systems.com)

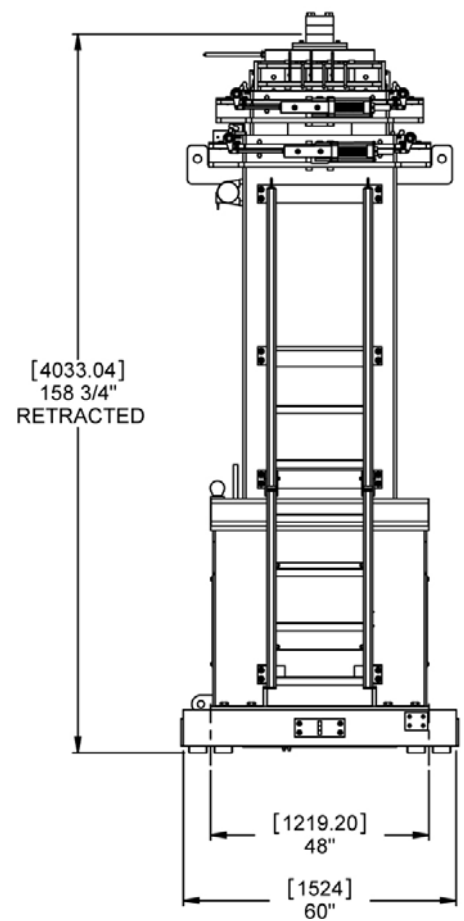
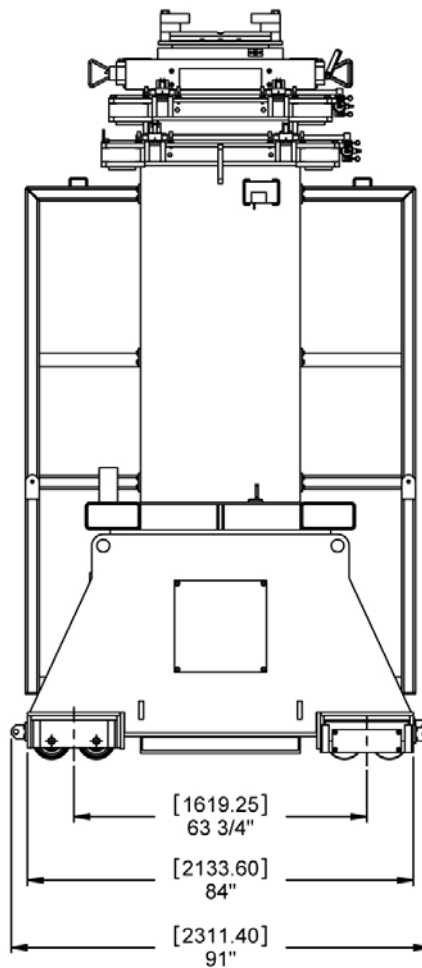
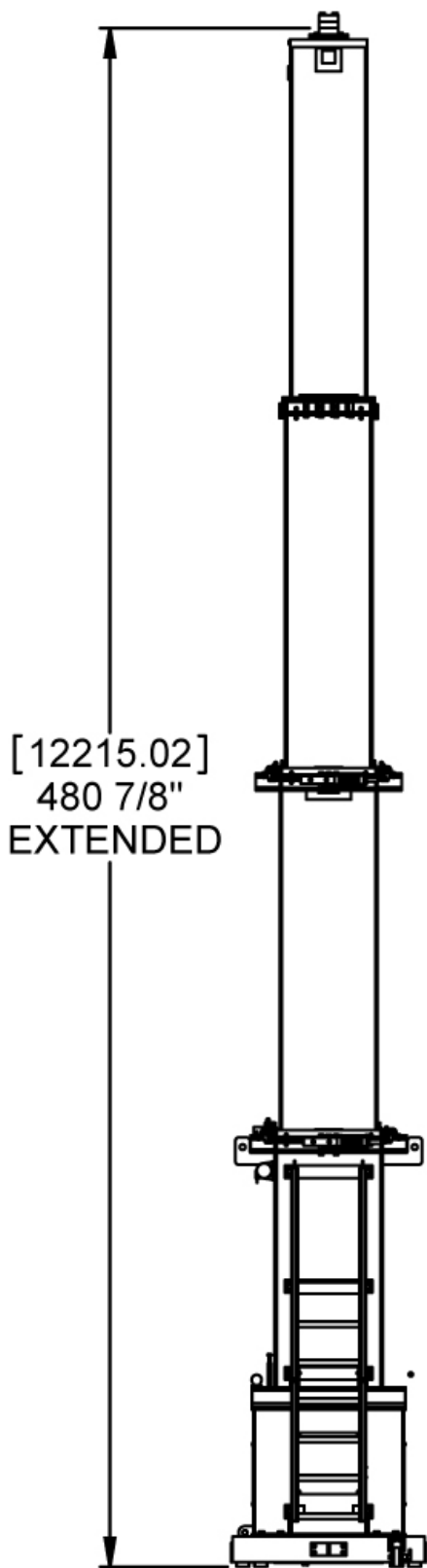

## MODEL 34PT6550WXT

Metric dimensions [mm]

### OPTIONAL EQUIPMENT AND FEATURES

- Integral Drives
- Changeable Power - Diesel to Electric in Minutes
- Digital Height Indicator
- Digital Load Weight Indicator
- Fully Powered Side Shift Systems
- Leveling Systems
- CARL Computerized Synchronization System
- Radio Remote Control
- Powered Rotators
- Adjustable Lifting Links
- Runway Track
- Track Stands
- Stator Frames
- Lifting Beams with Certified Load Charts
- Training Technicians

### LIFT SYSTEMS, INC.

OFFICE:  
1505 - 7th Street  
East Moline, IL 61244

MAILING ADDRESS:  
P.O. Box 906  
Moline, IL 61266

TEL: +1-309-764-9842  
FAX: +1-309-764-9848  
EMAIL: [info@lift-systems.com](mailto:info@lift-systems.com)  
WEB: [www.lift-systems.com](http://www.lift-systems.com)