



MODEL 34PT5400WXT-4

500 Ton POWER TOWER Gantry System

CAPACITY:

4 Point

500 (450) Tons to 30'3" (9,223 mm)
400 (360) Tons to 38'4" (11,684 mm)

2 Point

250 (225) Tons to 30'3" (9,223 mm)
200 (181) Tons to 38'4" (11,684 mm)

Max. Operating PSI: 2700 (186 bar)

BASE DIMENSIONS:

Length: 91.5" (2324 mm)
Width: 48" (1219 mm)
Height Retracted: 13'2" (4016 mm)
Weight: 17,000 lbs. (7720 kg)

POWER UNITS:

Two (2) 300 gallon (1136 L) Power Units
per Four Point System

Power Options: Diesel, Gasoline,
Propane, Electric (3 phase, 440 Volt,
60 Hz; or 3 Phase, 380 Volt, 50Hz)

Length: 92.5" (2350 mm)
Width: 61.5" (1562 mm)
Height: 61" (1549 mm)
Weight: 5250 lbs. (2384 kg)

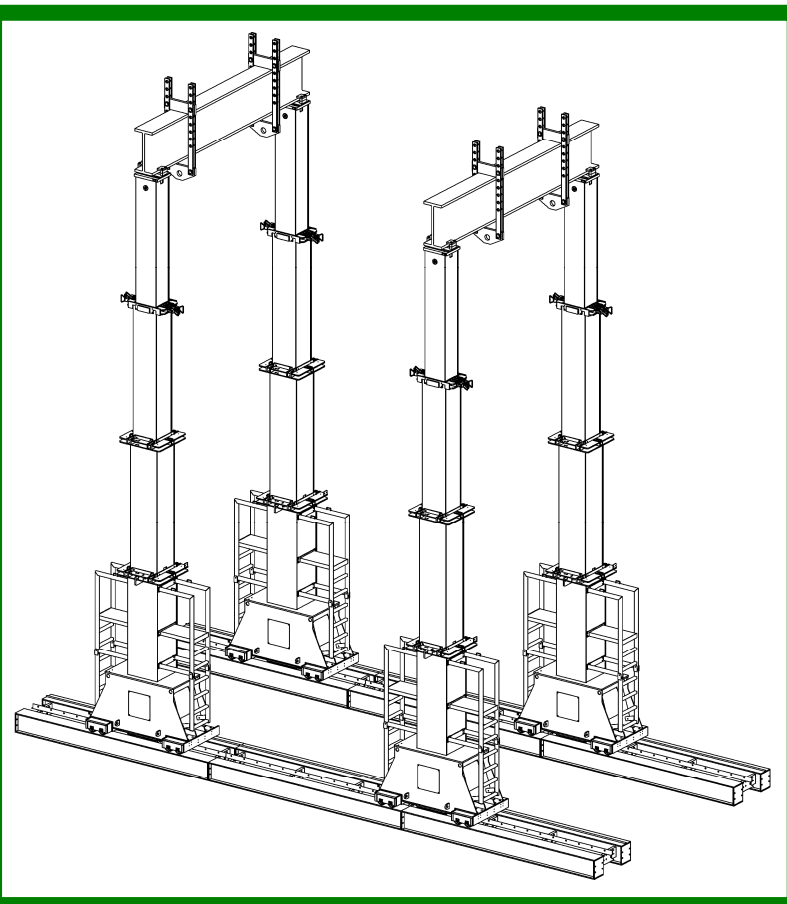

STANDARD FEATURES

- Straightest Booms in the Industry
- Large Lift Lugs
- Safety Holding Valves
- Wedge Inter-Lock System
- Large Work Platforms
- Double Acting Cylinders

LIFT SYSTEMS, INC.

OFFICE:
1505 - 7th Street
East Moline, IL 61244

MAILING ADDRESS:
P.O. Box 906
Moline, IL 61266

TEL: +1-309-764-9842
FAX: +1-309-764-9848
EMAIL: liftit@lift-systems.com
WEB: www.lift-systems.com

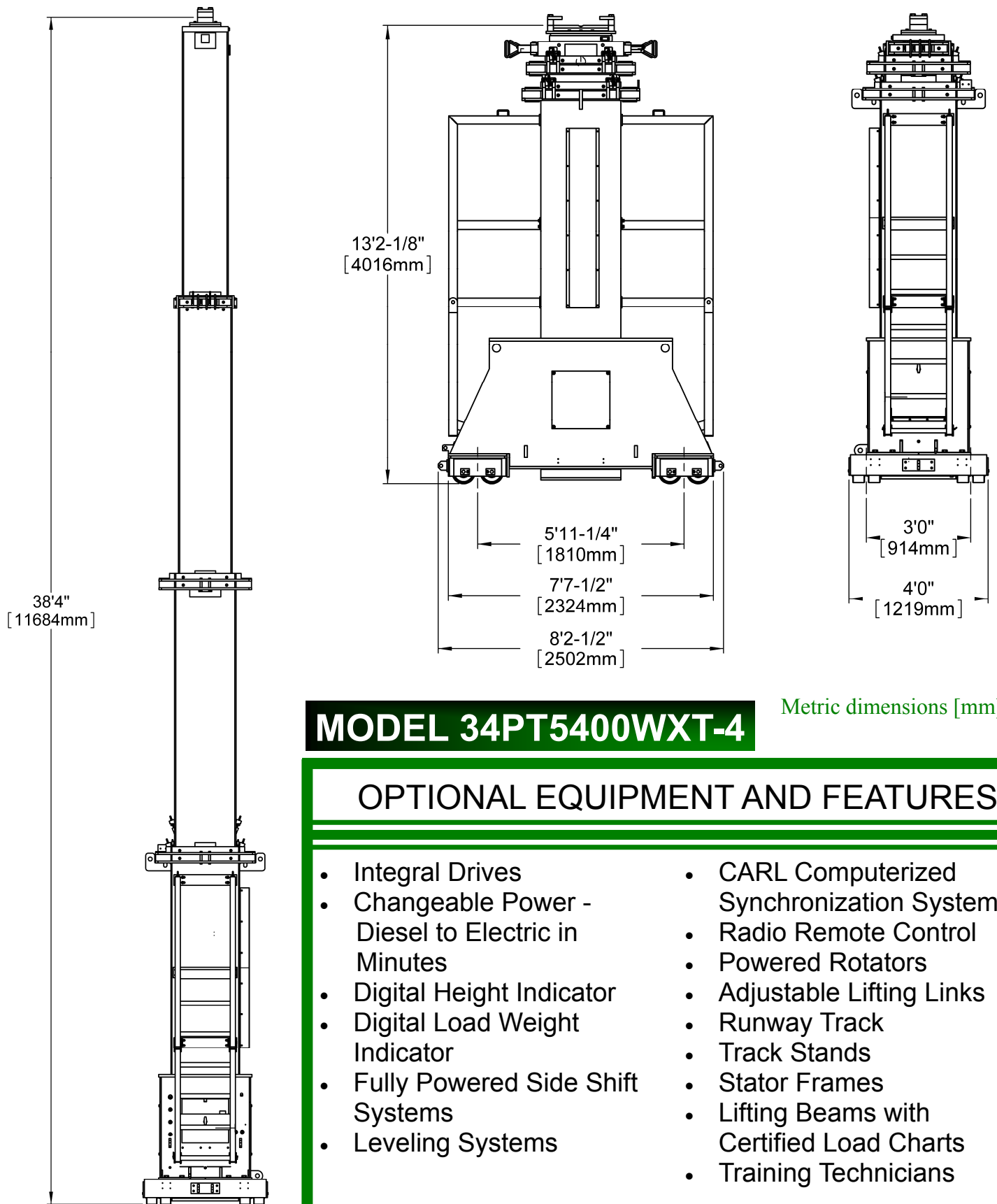

MODEL 34PT5400WXT-4

Metric dimensions [mm]

OPTIONAL EQUIPMENT AND FEATURES

- Integral Drives
- Changeable Power - Diesel to Electric in Minutes
- Digital Height Indicator
- Digital Load Weight Indicator
- Fully Powered Side Shift Systems
- Leveling Systems
- CARL Computerized Synchronization System
- Radio Remote Control
- Powered Rotators
- Adjustable Lifting Links
- Runway Track
- Track Stands
- Stator Frames
- Lifting Beams with Certified Load Charts
- Training Technicians

LIFT SYSTEMS, INC.

OFFICE: 1505 - 7th Street East Moline, IL 61244	MAILING ADDRESS: P.O. Box 906 Moline, IL 61266	TEL: +1-309-764-9842 FAX: +1-309-764-9848 EMAIL: liftit@lift-systems.com WEB: www.lift-systems.com
--	---	--